



主軸測試棒系列
Spindle Master Bar Series

高精度 高穩定

High precision, high stability.

精密型
Precision

偏擺精度 < 0.003mm
Runout within 0.003mm

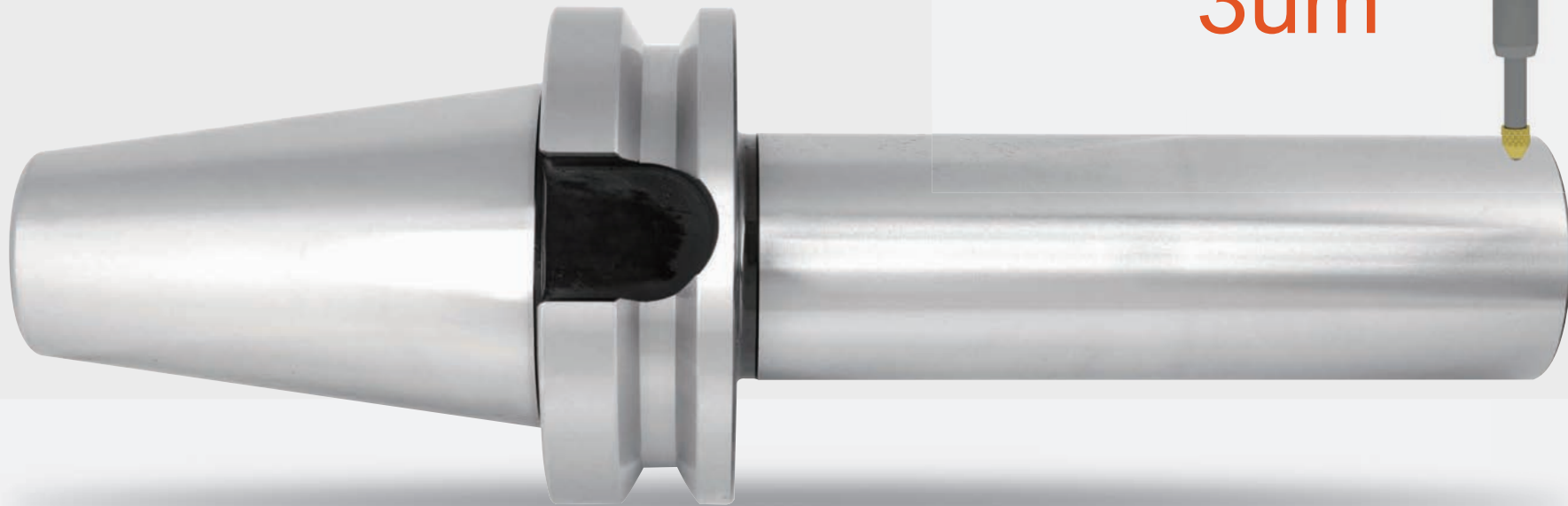

3um

定期的機械主軸精度檢測，可預防不良加工問題的出現
Regular mechanical spindle precision detection to prevent the occurrence of bad processing problems.

標準型
Standard

偏擺精度 < 0.005mm
Runout within 0.005mm



5um

SBT 主軸精密標準棒

SBT Spindle Master Bar

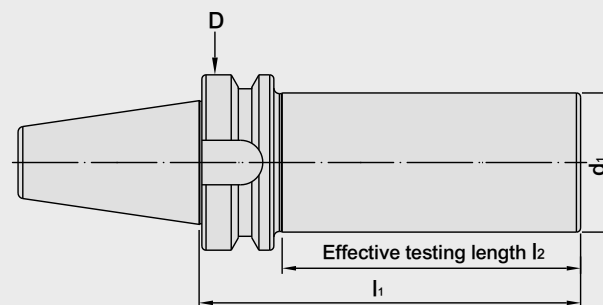

	錐度精度 Taper Precision	AT2
	真圓度	0.8um
	表面粗糙度 Surface Roughness	Ra<0.15um
	偏擺精度 Runout	3um
	圓柱度 Cylindrical	5um

規格 Spec.	l1	l2	D	d1	重量 (KGS) Weight
SBT30x25-250	215	180	32	1	2.86
SBT30x32-150	282	240	32	1	-
SBT30x32-235	374	300	40	3	3.66
SBT40x50-200	395	300	50	3	7.61
SBT40x50-350	195	175	20	2	-
SBT50x50-200	215	180	20	2	2.38
SBT50x50-360	215	180	32	2	2.98
SCAT40x50-300	282	240	32	2	3.70
SCAT50x50-300	367	300	40	4	4.48

PSC 主軸精密標準棒

PSC Spindle Master Bar

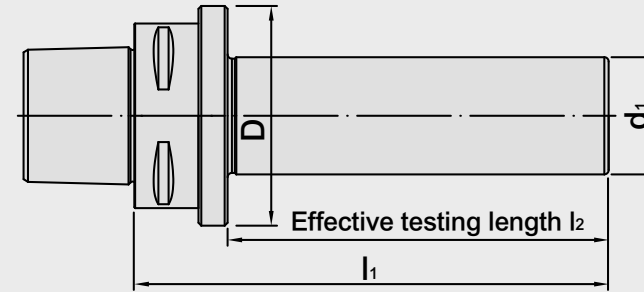

	錐度精度 Taper Precision	AT2
	真圓度 Roundness	0.001mm
	表面粗糙度 Surface Roughness	Ra<0.4
	同心度 Concentricity	0.005mm

規格 Spec.	l1	l2	D	d1	重量 (KGS) Weight
PSC32x20-180	180	165	32	20	0.41
PSC40x32-180	180	160	40	32	1.08
PSC50x32-180	180	150	63	32	1.38
PSC50x32-245	245	215	63	32	1.7
PSC50x40-280	280	250	63	40	2.12
PSC63x20-182	182	150	75	40	1.93
PSC63x20-232	232	200	75	40	4.02
PSC63x20-352	352	320	75	40	2.93

HSK 主軸精密標準棒

HSK Spindle Master Bar

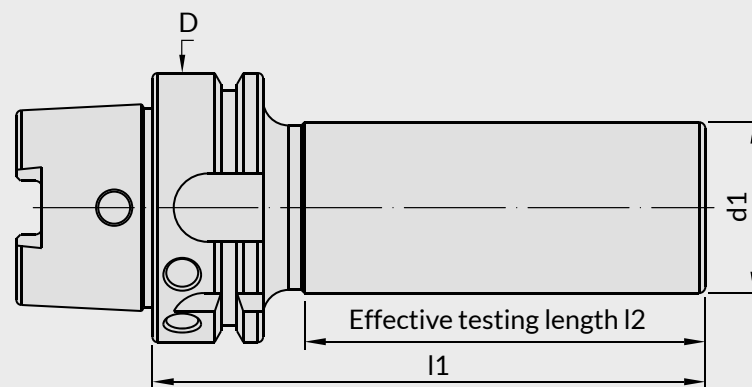

	錐度精度 Taper Precision	AT2
	真圓度 Roundness	0.8um
	表面粗糙度 Surface Roughness	Ra<0.15um
	偏擺精度 Runout	3um
	圓柱度 Cylindrical	5um

規格 Spec.	l1	l2	d1	重量 (KGS) Weight	Fig.
HSK40Ax32-200	200	170	32	2.86	1
HSK40Ax32-300	300	270	32	1.77	1
HSK50Ax32-240	240	211	32	1.44	1
HSK50Ax32-300	300	274	32	2.83	1
HSK63Ax40-346	346	300	40	3.66	1
HSK80Ax50-200	200	168	50	3.13	1
HSK80Ax50-350	350	318	50	4.83	1
HSK100Ax40-349	349	300	40	7.61	1
HSK100Ax50-349	349	300	50	5.64	1

HSK 主軸精密標準棒

HSK Spindle Master Bar

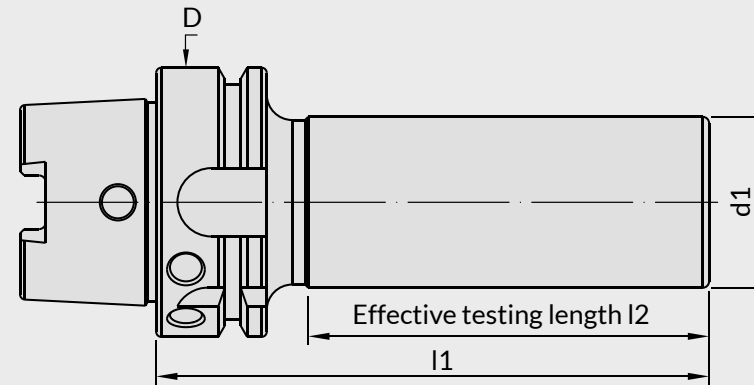

	錐度精度 Taper Precision	AT2
	真圓度 Roundness	0.8um
	表面粗糙度 Surface Roughness	Ra<0.15um
	偏擺精度 Runout	3um
	圓柱度 Cylindrical	5um

規格 Spec.	l1	l2	d1	重量 (KGS) Weight	Fig.
HSK25Ex25-175	175	163	25	0.58	2
HSK32Ex20-180	180	158	20	0.41	2
HSK40Ex32-180	180	157	32	2.98	2
HSK50Ex32-180	180	151	32	3.7	2
HSK63Fx40-346	346	300	40	4.48	2
HSK63Fx40-346	346	300	40	4.48	3

標準測試棒

Test Bar

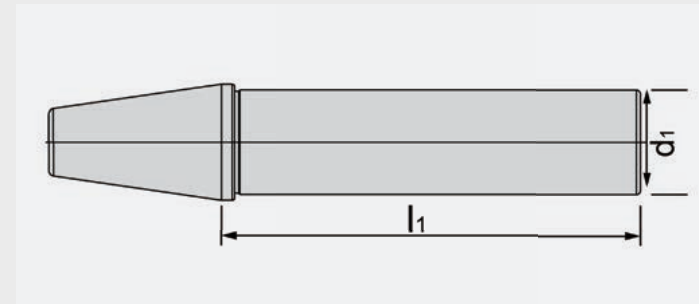

特點 Feature

- 皆通過真圓度測試機，精確檢驗通過
- 附精度檢驗表

- Have passed the roundness testing machine, exact test passed.
- With precision test table.

	錐度精度 Taper Precision	AT2
	真圓度 Roundness	0.001mm
	表面粗糙度 Surface Roughness	Ra<0.4
	同心度 Concentricity	0.005mm

規格 Spec.	l1	d1	同心度 Concentricity	真圓度 Roundness	重量 (KGS) Weight
BT30-TS250L	250	32	0.005	0.001	3.59
BT40-TS300L	300	40	0.005	0.001	3.64
BT50-TS300L	300	40	0.005	0.001	5.44

標準測試棒

Test Bar

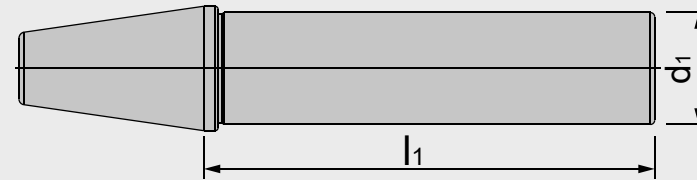

特點 Feature

- 皆通過真圓度測試機，精確檢驗通過
- 附精度檢驗表

- Have passed the roundness testing machine, exact test passed.
- With precision test table.

	錐度精度 Taper Precision	AT2
	真圓度 Roundness	0.001mm
	表面粗糙度 Surface Roughness	Ra<0.4
	同心度 Concentricity	0.005mm

規格 Spec.	l1	d1	同心度 Concentricity	真圓度 Roundness	重量 (KGS) Weight
DAT40 - TS300L	13	10	9.6	7	0.01

標準測試棒

Test Bar



Fig.1

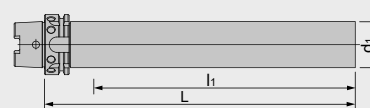

Fig.2

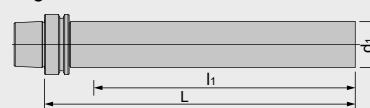

Fig.3

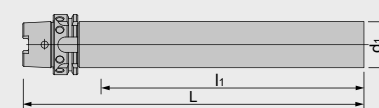
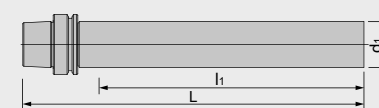

Fig.4



	錐度精度 Taper Precision	AT2
	真圓度 Roundness	0.001mm
	表面粗糙度 Surface Roughness	Ra<0.4
	同心度 Concentricity	0.005mm

規格 Spec.	L	l1	d1	Fig.	重量 (KGS) Weight
HSK40A-TS180L	215	180	32	1	2.86
HSK50A-TS240L	282	240	32	1	-
HSK63A-TS300L	374	300	40	3	3.66
HSK100A-TS300L	395	300	50	3	7.61
HSK25E-TS175L	195	175	20	2	-
HSK32E-TS180L	215	180	20	2	2.38
HSK40E-TS180L	215	180	32	2	2.98
HSK50E-TS240L	282	240	32	2	3.70
HSK63F-TS300L	367	300	40	4	4.48

標準測試棒

Test Bar

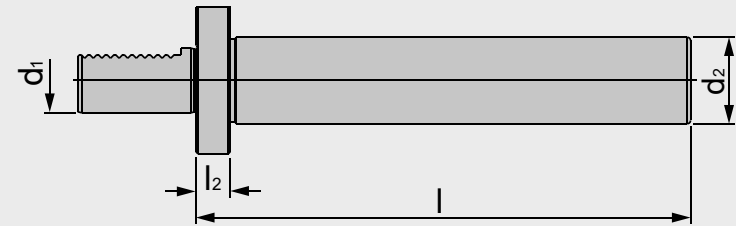
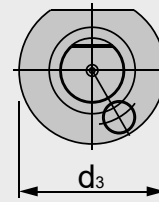

	錐度精度 Taper Precision	AT2
	真圓度 Roundness	0.001mm
	表面粗糙度 Surface Roughness	Ra<0.4
	同心度 Concentricity	0.005mm

規格 Spec.	尺寸 Size d1xd2xl1	l1	l2	d1	d2	d3	重量 (KGS) Weight
150.30.40.230	30x40x230	230	16	30	40	68	4.30
150.40.40.200	40x40x200	200	16	40	40	83	-
150.50.40.200	50x40x200	200	15	50	40	98	-



正河源股份有限公司
CHAIN HEADWAY CO.,LTD.

☎ TEL : +886-4-26265252

☎ FAX : +886-4-26267941

📍 地址 : 台灣台中市清水區五權路232號
No. 232, Wuquan Rd., Qingshui Dist., Taichung City 436, Taiwan

🌐 網址 : www.chain-headway.com



Website(中文)



Website(EN)



LINE



Whatsapp



Wechat



Facebook



YouTube

公司聯絡資訊請貼於此處
Company Information Please Paste here

其他服務據點訊息請透過官網查詢
Other Sales Region Please Review Our Website